

# BAIT

(Hebräisch für Haus)

Rachel Kohn (Skulptur) – Olaf Kühnemann (Malerei) – Andrea Morein (Mixed Media)

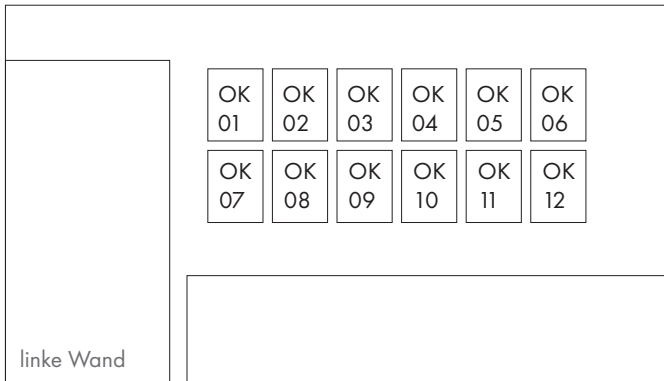

Olaf Kühnemann (OK)

HAUS 01-06 (obere Reihe)

HAUS 07-12 (untere Reihe)

HAUS 13-16 (Stirnwand)

HAUS 17-19 (rechte Wand)

je 30 x 40 cm

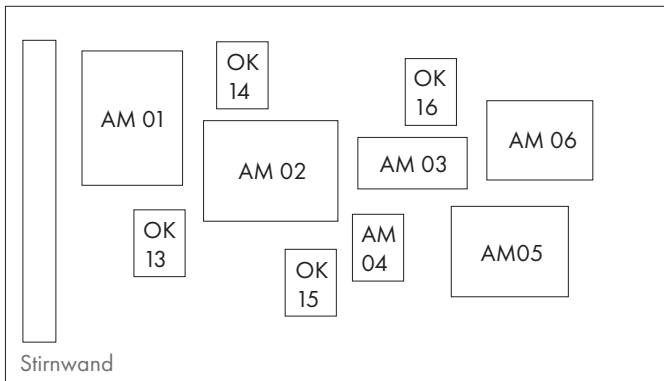

Andrea Morein (AM)

01 Locus #1, Archival print, 80 x 60 cm

02 Locus #2, Archival print, 56 x 80 cm

03 Shkiyah (Dusk), Collage, 72 x 32 cm,

04 Poetic Stanzas J.B., Collage, 33 x 43 cm,

05 BAIT, Drawing, 80 x 60cm

06 ‚Church of Purification, Jerusalem‘,

Collage, 70 x 50 cm

Rachel Kohn (RK)

01 Bergstation, 2017, Steinzeug, 64 x 62 x 27 cm

02 Kurort, 2015, Steinzeug, 33 x 21 x 23 cm

03 Zwischensaison, 2017, Steinzeug, 53 x 39 x 18 cm

RK 03

RK 02

RK 01

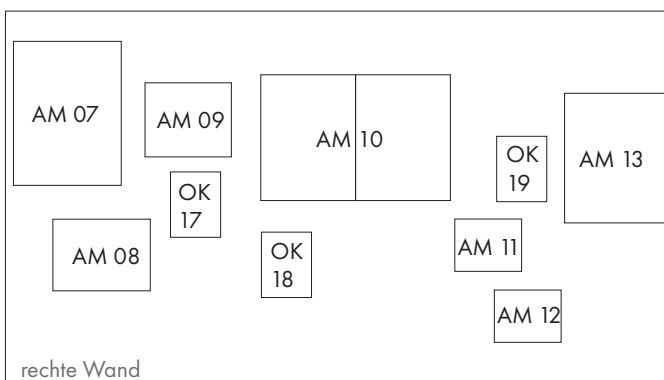

Andrea Morein

07 Shelter Shade, Archival print, 60 x 80 cm

08 Effacement #3, Fine Art Print, 50 x 40 cm

09 Messiah Collage, Mixed media, 50 x 40 cm

10 Right of (no) Return, Dyptich; 60 x 80cm each

11 Fort von Hier..., Text-drawing 40 x 30 cm

12 Groundplan Green, Mixed media, 30 x 40 cm

13 Locus #3, Archival print, 56 x 80 cm

14 Groundplan Blue, Collage, 50 x 40 cm

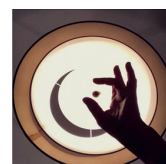
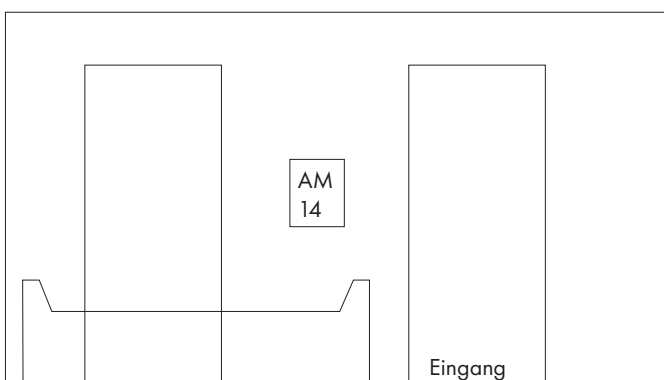

ODALISQUE –

Raum für Kunst & Embodiment

Goethestraße 84 | 10623 Berlin |

info@andreamorein.com | Kontakt:

+49 179 461 55 45